



INSTRUCTIONS

MODE D'EMPLOI

BEDIENUNGSANLEITUNG

MANUALE D'USO

INSTRUCCIONES DE USO

DIAL GAUGE **E**

COMPARATEUR **F**

MESSUHR **D**

COMPARATORE **I**

COMPARADOR **S**

**Installing and replacing the battery
(or Power cable)**



Mise en place et remplacement de la
batterie (ou câble Power)

**Einbau und Austausch von Batterie
(oder Netzkabel)**

Installazione e sostituzione della batteria
(o del cavo di alimentazione)

**Colocación y sustitución de la batería
(o cable Power)**



No. 0  No. 0 (0,4x2,5mm) 



Battery / batterie / **batterie** / batteria / **bateria** : lithium 3V, type CR2032

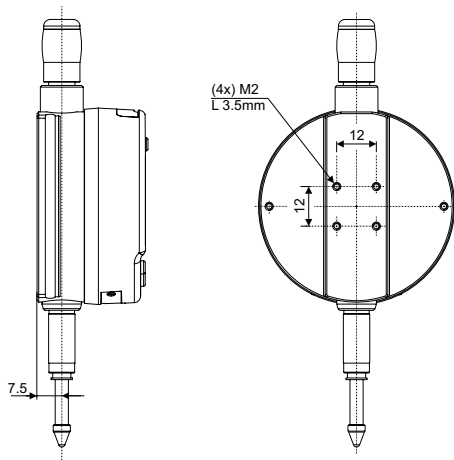

Diagram for rear fixings

Schéma de fixation arrière

Schema für die Befestigung hinten

Schema di fissaggio posteriore

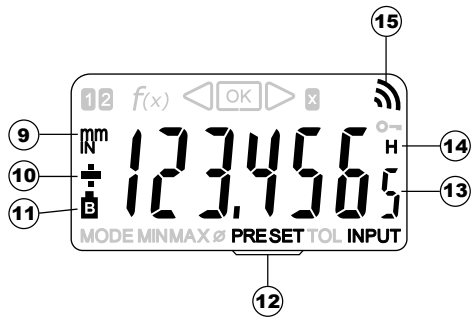
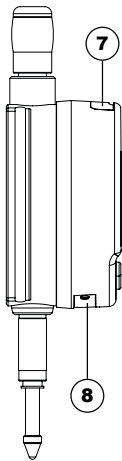
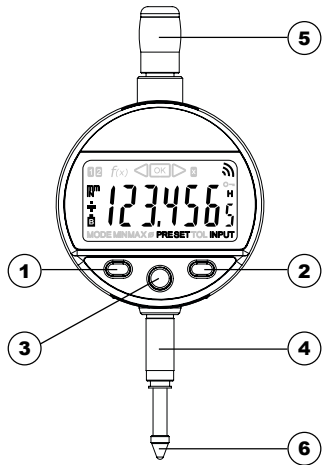

Esquema de fijación posterior

E

Description

1. MODE button
2. SET button
3. "Favourite" button
4. Clamping shaft Ø8 or 3/8"
5. Lifting cap
6. Contact point Ø2/M2.5 or 4-48-UNF
7. Slot for Proximity cable
8. Slot for battery or Power Cable
9. Measurement units (mm/INCH)
10. +/- Indicator
11. Low battery
12. Preset mode
13. 6-digit display
14. Hold measured value
15. Send data

1 . Operating features of the instrument

-  The «Mode» key gives access to the functions (units, preset and direction of measurement)
-  The «favourite» key gives direct access to the function used most often (see chap. 5)
-  Sets a Preset value, verifies a selection, and controls switching off the instrument. By default, SIS mode enables automatic switch-off with no loss of origin (see chap. 6)

- Personalising the functions

It is possible to activate or de-activate certain functions of the instrument via RS232 (see chap. 8)

- Data transmission parameters

4800Bds, 7 bits, even parity, 2 stop bits

2. Start

Press a button... then measure.

3. Basic functions

Each short press on **MODE** gives direct access to the basic functions:

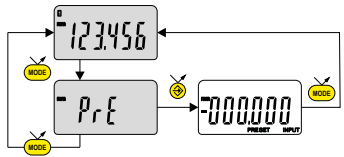

..... Inputting a Preset value

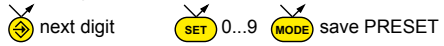

4. Additional functions

A long press (>2s) on **MODE** accesses additional functions. Each short press **MODE** then accesses the desired function:

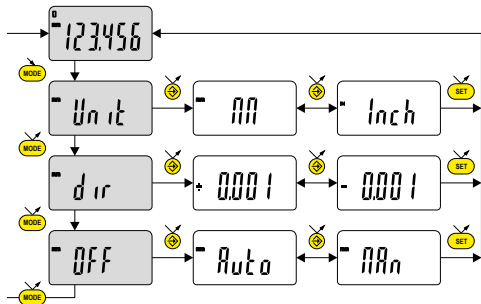
E

..... Units selection (mm or Inch)



..... Choice of measurement direction (positive or negative sense)

..... Automatic switch-off mode
Off = de-activated. *Auto* = active (after 10 min.)

5. Favourite key

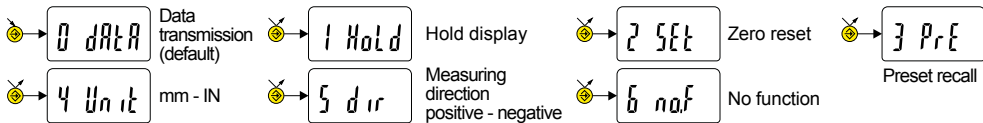
The «favourite» key gives direct access to a predefined function, and can be configured according to the needs of the user. In order to assign a function to the «favourite» key, give a prolonged press on , and then select the required function:





Validation of selection: By a prolonged press on , or a short press on  or 

Note: a function can also be assigned via RS232 using the command <FCT + Function No.> (FCT 0...3)
 example: Hold display = <FCT1>

6. Switching off

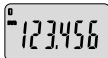
The dial gauge goes automatically into stand-by if not used for 10 minutes.

Stand-by mode can be forced by a prolonged press (> 2 sec) on :   >2s 



In stand-by mode, the value of the origin is retained by the sensor (SIS mode), and the instrument automatically restarts with any movement of the measurement probe, RS command or press a button.

E

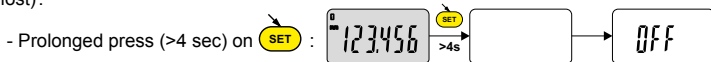
The instrument can be switched off completely for a long period of non-use, but this will necessitate a zero reset on restart (the origin will be lost):



7. Re-initialising the instrument

The initial instrument settings can be restored at any time by a prolonged press (>4 sec) simultaneously on  and  until the message *RESET* is displayed.

Nevertheless the instrument retains its configuration settings (units and resolution).

8. Personalising the instrument

Access to the functions of your instrument can be personalised, for more information see manufacturer's website (requires you to connect your instrument via a Proximity or Power RS / USB cable).

Possibilities:

- Enable or disable the required functions

9. Connecting the instrument

The instrument can be connected to a peripheral via a Proximity (RS or USB), Power (RS or USB). See page 2 for connecting the Power cable.

Measured values can be transmitted and the instrument driven using predefined commands (see chap. 10 for a list of the main commands)

10. List of the main commands

Selection and configuration

CHA+ / CHA-	Change measurement direction
FCT0 ...9...A...F	Assign «favourite» function
MM / IN	Change measurement unit
PRE [+/-]xxx.xxx	Modify preset value
STO1 / STO0	Activate / de-activate HOLD
LCAL dd.mm.yy	Modify last calibration date
NCAL dd.mm.yy	Modify next calibration date
UNI1 / UNI0	Activate / de-activate change of units
OUT1 /OUT0	Activate / de-activate contin. data transmission
PRE ON / PRE OFF	Activate / de-activate Preset function
PRE	Recall Preset
SET	Zero reset
RES2 / RES3	Change of resolution
SBY xx	Number of minutes before stand-by

Interrogation

CHA?	Measurement sense?
FCT?	«favourite» function active?
UNI?	Measurement unit active?
PRE?	Preset value?
STO?	Status of HOLD function?
LCAL?	Date of last calibration?
NCAL?	Date of next calibration?
?	Current value (mode Tol, value followed by <=>)
SET?	Main instrument parameters?
ID?	Instrument identification code?

Maintenance functions

BAT?	Battery status (BAT1 = OK, BAT0 = low battery)
OFF	Switch-off (wake up using a button or RS)
RST	Re-initialisation of the instrument
SBY	Put instrument in stand-by (SIS)
VER?	Version No. and date of firmware

11. Specifications

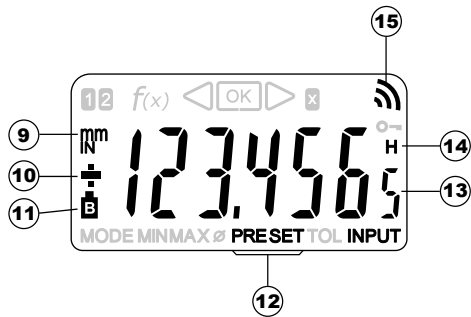
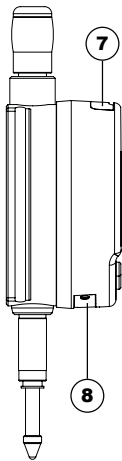
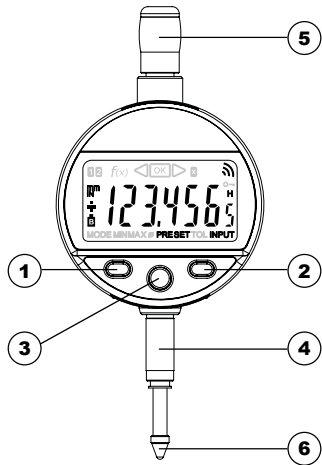

Measurement range:	12.5mm	25mm	50mm	100mm	150mm	
Max error (0.01mm scale):	10 μ m	10 μ m	20 μ m	20 μ m	20 μ m	(\pm 1 digit)
Max error (0.001mm scale):	4 μ m	5 μ m	7 μ m	8 μ m	10 μ m	
Repeatability:	2 μ m					
Weight:	119g	123g	161g	208g	265g	
Measurement force (standard):	0.65-0.9N	0.65-1.15N	1.25-2.7N	1.6-3.5N	2.2-5.7N	
Max. speed of travel:	1.7m/s					
No. of measurements/ sec:	measurement: 10 mes/s MIN/MAX mode: 20 mes/s					
Measurement unit:	metric/english (Inch)					
Maximum Preset (0.01mm scale):	\pm 9999.99 mm / \pm 399.9995 IN					
Maximum Preset (0.001mm scale):	\pm 999.999 mm / \pm 39.99995 IN					
Measurement system:	Sylvac inductive system (patented)					
Power:	1 x 3V lithium battery, type CR2032, 220mAh					
Average consumption:	75 μ A					
Average battery life:	8'000 hours					
Data output:	RS232 compatible					
Working temperature (storage):	+5 to +40°C (-10 to +60°C)					
Electromagnetic compatibility:	as per EN 61326-1					
IP rating (in accordance with IEC60529):	IP 51 / IP 67 (depending on model)					
Fixing and space envelope:	\varnothing 8 h6 (3/8"), interchangeable M2.5 (4-48-UNF) probe (as per DIN 878)					

F

Description

1. Bouton MODE
2. Bouton SET
3. Bouton " Favoris "
4. Canon de fixation Ø8 ou 3/8"
5. Bonnette de relevage
6. Touche à bille Ø2/M2.5 ou 4-48-UNF
7. Logement pour câble Proximity
8. Logement batterie ou câble Power
9. Unité de mesure (mm/INCH)
10. Indicateur +/-
11. Batterie faible
12. Mode Preset
13. Affichage 6 digits
14. Gel de la valeur de mesure
15. Envoi de données

1. Les fonctionnalités de l'instrument

-  Le bouton «Mode» permet de choisir la fonction désirée.
-  Le bouton «favori» permet d'attribuer un accès direct à la fonction principalement utilisée (voir chap. 5)
-  Le bouton «SET» permet d'attribuer une valeur de Preset, de quitter une sélection, et de gérer l'extinction de l'instrument. Par défaut, le mode SIS permet l'extinction automatique sans perte de l'origine (voir chap. 6).

- Personnalisation des fonctions

Vous avez la possibilité d'activer ou désactiver certaines fonctions de l'instrument par RS232 (voir chap. 8)

- Paramètres de transmission de données

4800Bds, 7 bits, parité paire, 2 stop bits

2. Démarrer



Pressez un bouton pour démarrer l'instrument.. puis mesurez.

3. Fonctions de base

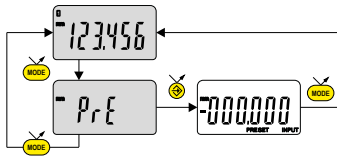
Chaque pression courte sur  permet un accès direct aux fonctions de base :





..... Introduction d'une valeur de Preset

 prochain digit  0...9  sauve le PRESET

F

4. Fonctions additionnelles

Une pression longue (>2s)  sur permet d'accéder aux fonctions additionnelles. Puis, chaque pression courte sur  accède à la fonction souhaitée :

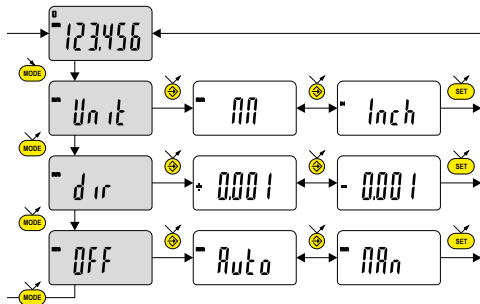

..... Sélection de l'unité (mm ou Inch)

..... Choix de la direction de mesure (sens positif ou négatif)

..... Mode d'extinction automatique
RRn = désactivé, *Auto* = actif (après 10 min.)



5. Touche favori

La touche «favori» permet l'accès direct à une fonction prédéfinie et peut être configurée selon les besoins de l'utilisateur.

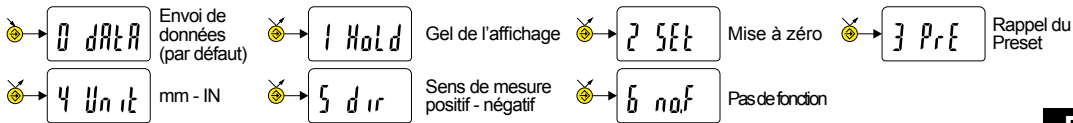
Pour attribuer une fonction à la touche «favori», effectuer une pression longue (>2s) sur , puis sélectionner la fonction souhaitée :



F

Validation de la sélection : Par une pression longue sur , ou une pression courte sur  ou 

Remarque : l'attribution de la fonction peut également se faire par RS 232, avec la commande <FCT + N° de fonction> (FCT 0...3) exemple : Gel de l'affichage = <**FCT1**>

6. Extinction

Le comparateur se met automatiquement en stand-by après 10 minutes de non utilisation.

Vous pouvez forcer le mode stand-by, par pression longue (>2s) sur  :

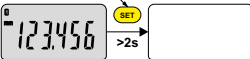



En mode stand-by, la valeur d'origine est conservée par le capteur (mode SIS), et l'instrument redémarre automatiquement par un mouvement de la touche de mesure ainsi que par commande RS, ou par pression sur un bouton.

Il est possible d'éteindre complètement l'instrument pour une longue période de non utilisation, mais cela nécessitera une remise à zéro à l'enclenchement (perte de l'origine):



F

7. Réinitialisation de l'instrument

A tout moment, il est possible de restaurer les réglages initiaux de l'instrument, par une pression longue (>4s) simultanée sur  et  jusqu'à l'affichage du message `rESt`.

L'instrument conserve néanmoins les réglages de configuration (unité et résolution).

8. Personnalisation de l'instrument

Il est possible de personnaliser l'accès aux fonctions de votre instrument, pour plus d'information voir site-web du fabricant (nécessite une connexion de votre instrument, via un câble Proximity ou Power RS / USB).

Possibilités :

- Désactiver ou activer les fonctions souhaitées

9. Connexion de l'instrument

L'instrument peut être connecté à un périphérique, via un câble Proximity (RS ou USB), ou Power-RS (Power-USB). Voir en page 2 pour la connexion des câbles.

Possibilité de transmettre les valeurs mesurées, et piloter l'instrument à l'aide de rétro-commandes prédéfinies (liste des commandes principales, voir chap. 10)

10. Liste des commandes principales

Sélection et configuration

CHA+ / CHA-	Changement direction de mesure
FCT0 ...9...A...F	Attribution fonction «favori»
MM / IN	Changement unité de mesure
PRE [+/-]xxx.xxx	Modification valeur de preset
STO1 / STO0	Active / désactive le HOLD
LCAL dd.mm.yy	Modifie date dernière calibration
NCAL dd.mm.yy	Modifie date prochaine calibration
UNI1 / UNI0	Active / désactive le changement d'unité
OUT1 / OUT0	Active / désact. transmission données en continu
PRE ON / PRE OFF	Active / désact. la fonction Preset
PRE	Rappel du Preset
SET	Mise à zéro
RES2 / RES3	Changement résolution
SBY xx	Nombre de minutes avant le Stand by

Interrogation

CHA?	Sens de mesure?
FCT?	Fonction «favori» active?
UNI?	Unité de mesure active?
PRE?	Valeur de preset?
STO?	Etat fonction HOLD?
LCAL?	Date dernière calibration?
NCAL?	Date prochaine calibration?
?	Valeur actuelle? (mode Tol, valeur suivie de <=>)
SET?	Paramètres principaux de l'instrument?
ID?	Code d'identification de l'instrument?

Fonctions de maintenance

BAT?	Etat pile (BAT1=Ok, BAT0=pile faible)
OFF	Extinct. complète (réveil par bouton ou RS)
RST	Réinitialisation de l'instrument
SBY	Mise en Stand by de l'instrument (SIS)
VER?	Révision et date du firmware

11. Spécifications

Etendue de mesure :	12.5mm	25mm	50mm	100mm	150mm	
Erreur max (échelon 0.01mm):	10µm	10µm	20µm	20µm	20µm	(±1 digit)
Erreur max (échelon 0.001mm):	4µm	5µm	7µm	8µm	10µm	
Répétabilité:	2µm					
Poids:	119g	123g	161g	208g	265g	
Force de mesure (standard):	0.65-0.9N	0.65-1.15N	1.25-2.7N	1.6-3.5N	2.2-5.7N	
Vitesse max. de déplacement:	1.7m/s					
Nbre de mesure par seconde:	mesure: 10 mes/s mode MIN/MAX: 20 mes/s					
Unité de mesure:	métrique/anglaise (Inch)					
Preset maximum (échelon 0.01mm):	±9999.99 mm / ±399.9995 IN					
Preset maximum (échelon 0.001mm):	±999.999 mm / ±39.99995 IN					
Système de mesure:	Sylvac inductive system (breveté)					
Alimentation:	1 batterie lithium 3V, type CR2032, capacité 220mAh					
Consommation moyenne:	75µA					
Autonomie moyenne:	8'000 heures					
Sortie de données:	compatible RS232					
Température de travail (stockage):	+5 à +40°C (-10 à +60°C)					
Compatibilité électromagnétique:	selon EN 61326-1					
Spécification IP (selon IEC60529):	IP 51 / IP 67 (selon modèle)					
Fixation et encombrement:	fixation Ø8h6 (3/8"), touche de mesure interchangeable M2.5 (4-48-UNF) (selon DIN 878)					

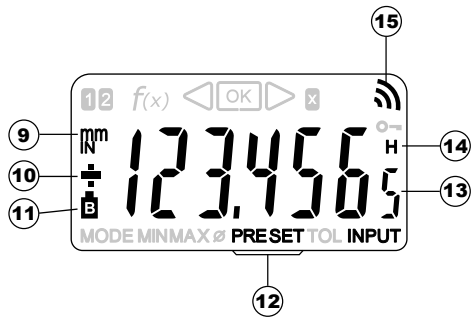
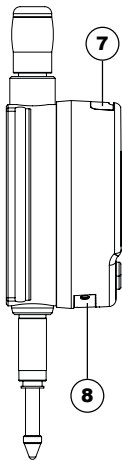
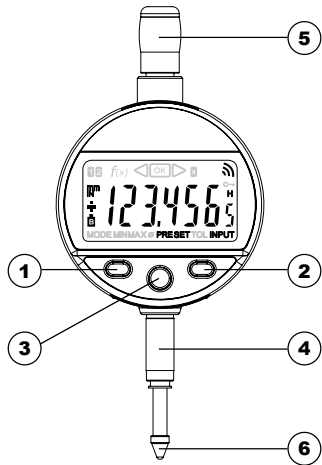

F

D

Beschreibung

1. MODE-Taste
2. SET-Taste
3. Favoriten-Taste
4. Einspannschaft Ø8 oder 3/8"
5. Abhebekapsel
6. Kugeltaster Ø2/M2.5 oder 4-48-UNF
7. Buchse für Proximity Kabel
8. Batterieeinschub oder Netzkabelbuchse
9. Masseinheit (mm/INCH)
10. +/- Anzeige
11. Batterie schwach
12. Preset-Modus
13. Anzeige von 6 Ziffern
14. Festhalten des Messwerts
15. Datenübertragung

1. Funktionalitäten des Instruments:

-  Mit der Taste Mode kann man die Funktionen zu wählen
-  Mit der Taste „Favoriten“ kann man der hauptsächlich verwendeten Funktion einen direkten Zugriff zuzuweisen (siehe Kap. 5)
-  Ermöglicht die Zuweisung eines Presetwertes, die Quittierung einer Auswahl und die Steuerung des Ausschaltens des Instruments. Der SIS-Modus ermöglicht standardmässig das automatische Ausschalten ohne Verlust der Anfangseinstellung (siehe Kap. 6).

D

- Personalisierung der Funktionen

Es ist möglich, einige Funktionen des Instruments über R232 zu aktivieren oder zu deaktivieren (siehe Kap. 8)

- Parameter für Datenübertragung

4800Bds, 7 Bits, gerade Parität, 2 Stoppbits

2. Starten



Eine Taste drücken... und messen Sie.

3. Grundfunktionen

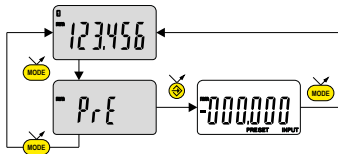
Jede kurze Betätigung von  ermöglicht einen direkten Zugriff auf die Grundfunktionen:



.....Eingabe des Presetwertes

 nächste Ziffer  0...9  PRESET speichern

4. Zusätzliche Funktionen

Ein langer Druck (>2s) auf  führt zu den Zusatzfunktionen. Danach führt jeder kurze Druck auf  zur gewünschten Funktion:

D

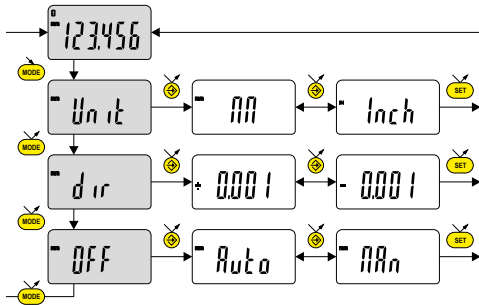
D

.....Wahl der Einheit (mm oder Inch)



.....Wahl der Messrichtung (positive oder negative Richtung)

.....Automatischer Ausschaltmodus
Off = deaktiviert, *Auto* = aktiv (nach 10 min.)

5. Favoriten-Taste

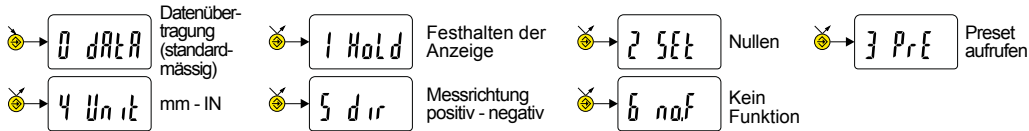
Die „Favoriten-Taste“ ermöglicht den direkten Zugriff auf eine zuvor bestimmte Funktion und kann entsprechend der Bedürfnisse des Nutzers konfiguriert werden. Um der „Favoriten-Taste“ eine Funktion zuzuordnen, muss man lange auf  drücken und dann die gewünschte Funktion wählen:





Bestätigung der Auswahl: Durch langes Drücken von  oder kurzes Drücken von  oder 

Anmerkung: Die Zuordnung der Funktion kann auch durch RS 232 erfolgen, mit der Steuerung <FCT + Funktions-Nr.> (FCT 0...3) Beispiel: Festhalten der Anzeige = <FCT1>

D

6. Ausschalten

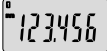
Die Messuhr stellt sich nach 10 Minuten Nichtgebrauch automatisch auf Stand-By.



Stand-By-Funktion durch langes Betätigen (>2s) von  erzwingen.    >2s

Im Stand-By-Modus wird der Referenzwert vom Sensor (SIS Modus) beibehalten und das Instrument startet automatisch mit einer Bewegung des Messeinsatzes sowie über RS, oder eine Taste drücken.

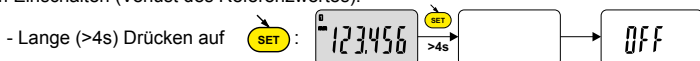
Es ist möglich, das Instrument für eine lange Zeit des Nichtgebrauchs vollständig auszuschalten, aber das erfordert eine Rückstellung beim Einschalten (Verlust des Referenzwertes).



7. Rücksetzen des Instruments

Man kann die Werkseinstellungen des Instruments jederzeit mit einem langen (>4s), gleichzeitigen Drücken bis zur Anzeige der Meldung *rE5Et* auf  und  wiederherstellen.

D

Das Instrument behält jedoch die Konfigurationseinstellungen (Einheit und Auflösung).

8. Personalisierung des Instruments

Es ist möglich, den Zugriff auf die Funktionen Ihres Instruments mit Hilfe der kostenlosen Software zu personalisieren. Weitere Informationen finden Sie auf der Webseite des Herstellers (erfordert den Anschluss Ihres Instruments mit einem Proximity-Kabel oder RS / USB Power).

Möglichkeiten:

- die Deaktivierung oder Aktivierung der erwünschten Funktionen

9. Anschluss des Instruments

Das Instrument kann mit einem Proximity-Kabel (RS oder USB) oder Power-RS (Power-USB) an ein Peripheriegerät angeschlossen werden. Informationen zum Kabelanschluss finden Sie auf Seite 2

Man kann die gemessenen Werte übertragen und das Instrument mit Hilfe von bestimmten Befehlen steuern. Liste der wesentlichen Steuerbefehle, siehe Kap. 10.

10. Liste der wesentlichen Steuerbefehle

Auswahl un Konfiguration

CHA+ / CHA-	Wechsel der Messrichtung
FCT0 ...9...A...F	Zuordnung der Funktion „Favorit“
MM / IN	Wechsel der Masseinheit
PRE [+/-]xxx.xxx	Änderung des Presetwertes
STO1 / STO0	Aktiviert / Deaktiviert den HOLD
LCAL dd.mm.yy	Ändert das Datum der letzten Kalibrierung
NCAL dd.mm.yy	Ändert das Datum der nächsten Kalibrierung
UNI1 / UNI0	Aktiviert / Deaktiviert den Einheitswechsel
OUT1 /OUT0	Aktiviert / Deaktiviert die kontinuierliche Datenübertragung
PRE ON / PRE OFF	Aktiviert /Deaktiviert die Presetfunktion
PRE	Preset-Rückstellung
SET	Nullen
RES2 / RES3	Ändern des Ziffernschrittwerts
SBY xx	Anzahl der Minuten bevor Stand-by

Abfragen

CHA?	Messrichtung?
FCT?	Funktion „Favorit“ aktiv?
UNI?	Masseinheit aktiv
PRE?	Presetwert?
STO?	HOLD Funktionsstatus?
LCAL?	Datum der letzten Kalibrierung?
NCAL?	Datum der nächsten Kalibrierung?
?	Aktueller Wert (Tol.-Modus, Wert gefolgt von <=>)
SET?	Hauptparameter des Instruments?
ID?	Identifizierungscode des Instruments?

Wartungsfunktionen

BAT?	Batteriestatus (BAT1=Ok, BAT0=Batterie schwach)
OFF	Vollständ. Ausschalten (Neuaktivierung mit Knopf oder RS)
RST	Rücksetzen des Instruments
SBY	Setzen des Instruments auf Stand-By (SIS)
VER?	Revision und Datum der Firmware



11. Spezifizierungen

Messbereich:	12.5mm	25mm	50mm	100mm	150mm	
Fehlergrenze (Stufe 0.01mm):	10µm	10µm	20µm	20µm	20µm	(±1 digit)
Fehlergrenze (Stufe 0.001mm):	4µm	5µm	7µm	8µm	10µm	
Wiederholbarkeit:	2µm					
Gewicht:	119g	123g	161g	208g	265g	
Messkraft (Standard):	0.65-0.9N	0.65-1.15N	1.25-2.7N	1.6-3.5N	2.2-5.7N	
Maximale Bewegungsgeschwindigkeit:	1.7m/s					
Anzahl der Messungen pro Sekunde:	Messung: 10 Mess/s		Betriebsart MIN/MAX: 20 Mess/s			
Masseinheit:	mm / Inch					
Maximum Preset (Stufe 0.01mm):	±9999.99 mm / ±399.9995 IN					
Maximum Preset (Stufe 0.001mm):	±999.999 mm / ±39.99995 IN					
Messsystem:	Sylvac inductive system (patentiert)					
Versorgung:	1 x 3 V Lithiumbatterie, Typ CR2032, Kapazität 220 mAh					
Durchschnittlicher Verbrauch:	75µA					
Durchschnittliche Autonomie:	8'000 Stunden					
Datenausgang:	RS232 kompatibel					
Arbeitstemperatur (Lagerung):	+5 bis +40°C (-10 bis +60°C)					
Elektromagnetische Verträglichkeit:	gemäß EN 61326-1					
IP Spezifikation (gemäß IEC60529):	IP 51 / IP 67 (je nach Modell)					
Befestigung und Platzbedarf:	Ø8h6 (3/8") Befestigung, austauschbarer M2.5 (4-48-UNF) Messeinsatz (gemäß DIN 878)					

D

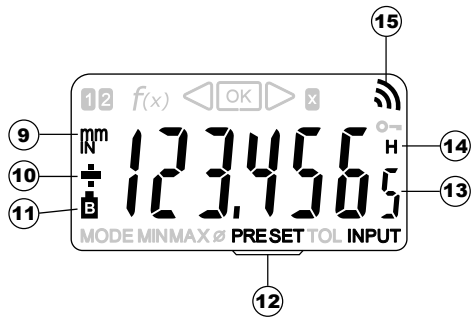
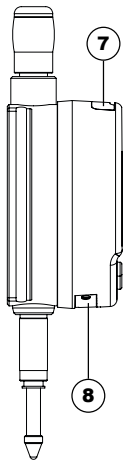
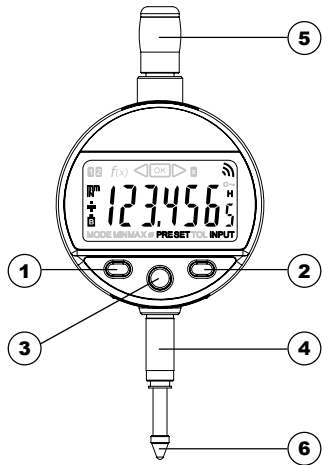

D



Description

1. Pulsante Modalità
2. Pulsante Impostazione
3. Pulsante « Preferiti »
4. Albero di fissaggio Ø8 o 3/8"
5. Elemento di sollevamento
6. Tasto a sfera Ø2/M2.5 o 4-48-UNF
7. Alloggiamento per cavo di Proximity
8. Alloggiamento batteria o cavo di alimentazione
9. Unità di misura (mm/INCH)
10. Indicatori +/-
11. Batteria scarica
12. Modalità Preset
13. Visualizzazione a 6 cifre
14. Congelamento del valore di misura
15. Invio dati

1. Funzionalità dello strumento

-  Il tasto «Modalità» permette l'accesso di funzione
-  Il tasto «preferito» permette di attribuire un accesso diretto alla funzione utilizzata maggiormente (consultare il capitolo 5)
-  Permette di attribuire un valore di Preset, di reinizializzare la modalità MIN/MAX, di confermare una selezione e di gestire lo spegnimento dello strumento. Per impostazione predefinita, la modalità SIS permette lo spegnimento automatico senza perdita dell'origine (consultare il capitolo 6)

- Personalizzazione delle funzioni

È possibile attivare o disattivare determinate funzioni dello strumento mediante RS232 (consultare il capitolo 8)

- Parametri di trasmissione dati

4800Bds, 7 bit, parità, 2 stop bit

2. Avvio



Premere un pulsante... e procedere alla misurazione.

3. Funzione di base

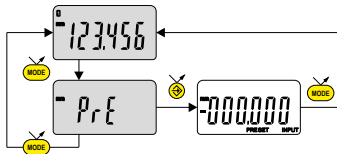
Ogni breve pressione su  permette l'accesso diretto alle funzioni base:



..... Inserimento di un valore di Preset

 cifra successiva  0...9  salva il PRESET

4. Funzioni aggiuntive

Premendo a lungo (>2s)  si accede alle funzioni aggiuntive. Successivamente, ogni breve pressione su  porta alla funzione desiderata:



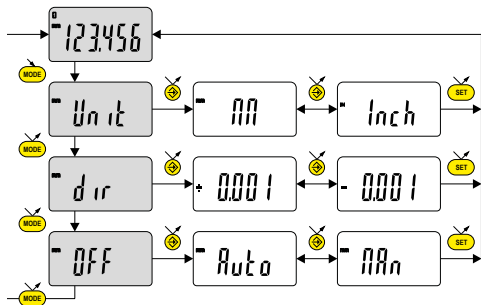

..... Selezione dell'unità (mm o Inch)



..... Scelta della direzione di misura (senso positivo o negativo)

..... Modalità di spegnimento automatico
RRn = disattiva, *Auto* = attiva (dopo 10 min.)

5. Tasto preferito

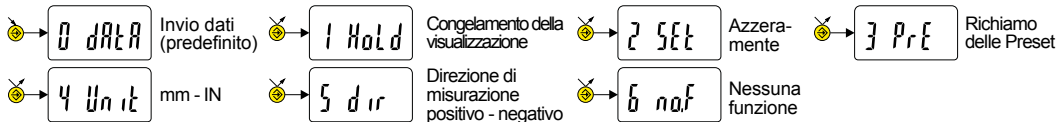
Il tasto «preferito» permette di accedere direttamente a una funzione predefinita e può essere configurato secondo le esigenze dell'utente. Per assegnare una funzione al tasto «preferito», applicare una pressione lunga su , quindi selezionare la funzione desiderata





Conferma della selezione: mediante pressione lunga su  , o una breve pressione su  o 

Nota: la funzione può essere assegnata anche mediante RS 232, con il comando <FCT + N° di funzione> (FCT 0...3)
 esempio: Congelamento della visualizzazione = <FCT1>

6. Spegnimento

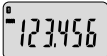
Il comparatore va automaticamente in stand-by dopo 10 minuti di inattività.



È possibile forzare la modalità stand-by, con una pressione lunga (>2s) su  :   >2s 

In modalità stand-by, il valore di origine è memorizzato dal sensore (modalità SIS), e lo strumento si riavvia automaticamente con un movimento del tasto di misura mediante il comando RS, o premere un pulsante.

È possibile spegnere completamente lo strumento per un lungo periodo di non utilizzo, ma sarà necessario un azzeramento al momento del collegamento (perdita dell'origine):



7. Reinizializzazione dello strumento

In qualsiasi momento è possibile ripristinare le impostazioni originali dello strumento con una pressione lunga (>4s) contemporanea su  e  fino a visualizzare il messaggio *reset*.

Lo strumento conserva tuttavia le impostazioni di configurazione (unità e risoluzione).

8. Personalizzazione dello strumento

È possibile personalizzare l'accesso alle funzioni dello strumento mediante il software gratuito, il sito web del produttore (lo strumento deve essere connesso, con un cavo Proximity o di alimentazione RS / USB).

Possibilità:

- Disattivare o attivare le funzioni desiderate

9. Connessione dello strumento

Lo strumento può essere connesso a una periferica mediante un cavo di prossimità (RS o USB), o di POWER-RS e POWER-USB. Vedere pagina 2 per il collegamento dei cavi.

È possibile trasmettere i valori misurati e comandare lo strumento con dei retro-comandi predefiniti (elenco dei comandi principali, consultare il capitolo 10)

10. Elenco dei comandi principali

Selezione e configurazione

CHA+ / CHA-	Modifica direzione di misura
FCT0 ...9...A...F	Assegnazione funzione «preferito»
MM / IN	Modifica unità di misura
PRE [+/-]xxx.xxx	Modifica valore di preset
STO1 / STO0	Attiva / disattiva HOLD
LCAL dd.mm.yy	Modifica data ultima calibratura
NCAL dd.mm.yy	Modifica data prossima calibratura
UNI1 / UNIO	Attiva / disattiva il cambio di unità
OUT1 /OUT0	Attiva / disatt. trasmissione dati continua
PRE ON / PRE OFF	Attiva / disatt. la funzione Preset
PRE	Richiamo del Preset
SET	Azzeramento
RES2 / RES3	Modifica risoluzione
SBY xx	Numero di minuti prima dello stand-by

Interrogazione

CHA?	Senso di misura?
FCT?	Funzione «preferito» attiva?
UNI?	Unità di misura attiva?
PRE?	Valore di preset?
STO?	Stato funzione HOLD?
LCAL?	Data ultima calibratura?
NCAL?	Data prossima calibratura?
?	Valore attuale (modalità Tol, valore seguito da <=>)
SET?	Parametri principali dello strumento?
ID?	Codice d'identificazione dello strumento?
Funzioni di manutenzione	
BAT?	Stato batteria (BAT1=Ok, BAT0=batteria scarica)
OFF	Spegnim. completo (riattivazione mediante pulsante o RS)
RST	Reinizializzazione dello strumento
SBY	Messa in Stand by dello strumento (SIS)
VER?	Revisione e data del firmware

11. Specifiche

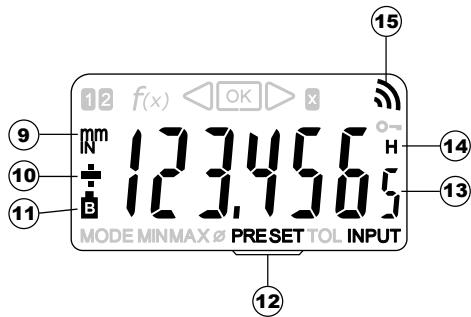
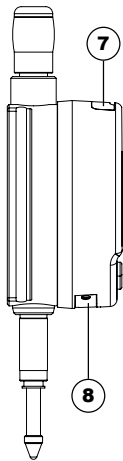
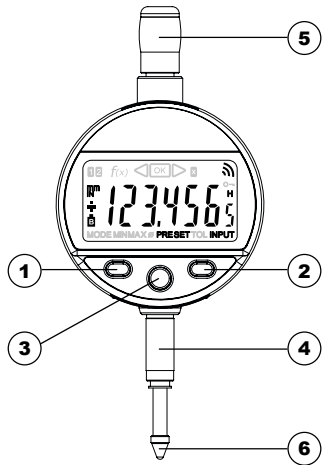

Campo di misura:	12.5mm	25mm	50mm	100mm	150mm	
Errore max (risoluzione 0,01 mm):	10µm	10µm	20µm	20µm	20µm	(±1 digit)
Errore max (risoluzione 0,001 mm):	4µm	5µm	7µm	8µm	10µm	
Ripetibilità:	2µm					
Peso:	119g	123g	161g	208g	265g	
Forza di misura (standard):	0.65-0.9N	0.65-1.15N	1.25-2.7N	1.6-3.5N	2.2-5.7N	
Velocità max. di spostamento:	1.7m/s					
N. di misure al secondo:	misura: 10 mis/s modalità MIN/MAX: 20 mis/s					
Unità di misura:	metrica/inglese (Inch)					
Preset massimo (risoluzione 0,01 mm):	±9999.99 mm / ±399.9995 IN					
Preset massimo (risoluzione 0,001 mm):	±999.999 mm / ±39.99995 IN					
Sistema di misura:	Sistema Sylvac induttivo (brevettato)					
Alimentation:	1 batteria al litio 3 V, tipo CR2032, capacità 220 mAh					
Consumo medio:	75µA					
Autonomia media:	8.000 ore					
Uscita dati:	compatibile RS232					
Temperatura operativa (stoccaggio):	da +5 a +40 °C (da -10 a +60 °C)					
Compatibilità elettromagnetica:	secondo EN 61326-1					
Specifica IP (secondo IEC60529):	IP 51 / IP 67 (in base al modello)					
Fissaggio e ingombro:	fissaggio Ø8h6 (3/8"), tasto di misura intercambiabile M2.5 (4-48-UNF) (secondo DIN 878)					



Description

1. Botón Modo
2. Botón Configuración
3. Botón « Favoritos »
4. Cañón de fijación Ø8 o 3/8"
5. Corona de elevación
6. Palpador de bola Ø2/M2.5 o 4-48-UNF
7. Alojamiento para cable Proximity
8. Alojamiento para batería o cable Power
9. Unidad de medida (mm/pulgadas)
10. Indicadores +/-
11. Batería baja
12. Modo Preset
13. Visualización de 6 dígitos
14. Congelación del valor de medición
15. Envío de datos

1. Funcionalidades del equipo

-  La tecla «Modo» permite de seleccionar la función deseada
-  La tecla «favorito» atribuye un acceso directo a la función utilizada de manera principal (ver cap. 5)
-  Atribuye un valor predefinido, reinicializa el modo MIN/MAX, borra una selección y gestiona el apagado del equipo. Por defecto, el modo SIS permite apagar de manera automática sin pérdida de original (ver cap. 6)

- Personalización de las funciones

Es posible activar o desactivar ciertas funciones del equipo por RS232 (ver cap. 8)

- Parámetros de transmisión de datos

4800Bds, 7 bits, paridad par, 2 bits de parada

2. Arranque

Pulse un botón... y mida

3. Funciones básicas

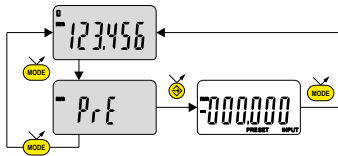

Cada pulsación breve sobre  permite acceder directamente a las funciones básicas:



..... Introducción de un valor predefinido

 dígito siguiente  0...9  guarda el valor predefinido (PRESET)

4. Funciones adicionales

Mantenga pulsado (>2s) para  acceder a las funciones adicionales. Cada pulsación corta  accede a la función deseada:

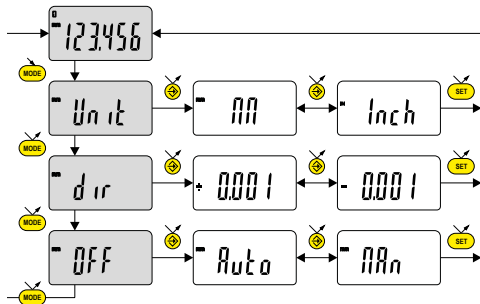

..... Selección de la unidad (mm o In)



..... Selección de la dirección de medición
(sentido positivo o negativo)

..... Modo de apagado automático
Off = desactivado, Auto = activo (tras 10 min.)

5. Tecla favorito

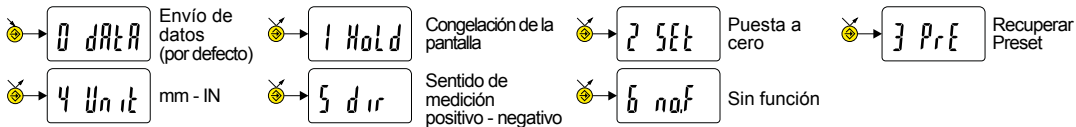
Con la tecla «favorito» se accede directamente a una función predefinida y puede configurarse según las necesidades del usuario. Para atribuir una función a la tecla «favorito» pulse prolongadamente sobre  y seleccione la función deseada:



Validación de la selección: Pulsando prolongadamente en  , o brevemente en  o en 

Observaciones: puede atribuirse también la función por RS232 con las teclas <FCT + N° de función> (FCT 0...3)
 ejemplo: Congelación de la pantalla = <FCT1>

6. Apagado

El comparador hibernará automáticamente tras 10 minutos de inactividad.

Es posible forzar el modo de hibernación pulsando prolongadamente (> 2 seg)

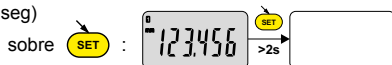



En modo hibernación el sensor conserva el valor original (modo SIS) y el equipo se reanuda automáticamente por un movimiento de la tecla de medición por control RS, o pulse un botón.



Es posible apagar el equipo en períodos largos en los que no se utilice pero esto implicará una puesta a cero al arranque de nuevo (pérdida del origen):



7. Reinicialización del equipo

Los ajustes iniciales del equipo pueden restaurarse en cualquier momento pulsando prolongadamente (> 4 seg) y al mismo tiempo que  y  hasta que se muestre el mensaje `rESt`.

El equipo conservará los ajustes de configuración (unidad y resolución).

8. Personalización del equipo

Es posible personalizar el acceso a las funciones de su equipo con el programa gratuito para más información, véase el sitio web del fabricante (requiere conexión de su equipo con cable Proximity o Power RS / USB).

Esta aplicación permite:

- Desactivar o activar las funciones deseadas

9. Conexión del equipo

El equipo puede conectarse a un periférico con un cable Proximity (RS o USB), o Power-RS (Power-USB). Consultar la página 2 para la conexión de los cables.

Los valores medidos pueden transmitirse y puede controlarse el instrumento con comandos predefinidos (lista de comandos principales en el cap. 10)

10. Lista de comandos principales

Selección y configuración

CHA+ / CHA-	Cambio de dirección de medición
FCT0 ...9...A...F	Atribución de función «favorito»
MM / IN	Cambio de unidad de medida
PRE [+/-]xxx.xxx	Modificación del valor predefinido
STO1 / STO0	Activa / desactiva el HOLD
LCAL dd.mm.yy	Modifica fecha de última calibración
NCAL dd.mm.yy	Modifica fecha de próxima calibración
UNI1 / UNI0	Activa / desactiva el cambio de unidad
OUT1 /OUT0	Activa / desact. transmisión continua de datos
PRE ON / PRE OFF	Activa / desactiva la función Preset
PRE	Recordatorio del Preset
SET	Puesta a cero
RES2 / RES3	Cambio de resolución
SBY xx	Cantidad de minutos antes de la espera

Pregunta

CHA?	¿Sentido de medición?
FCT?	¿Función «favorito» activada?
UNI?	¿Unidad de medida activada?
PRE?	¿Valor predefinido?
STO?	¿Estado de la función HOLD?
LCAL?	¿Fecha de última calibración?
NCAL?	¿Fecha de próxima calibración?
?	¿Valor actual (modo Tol, valor seguido de <=>)?
SET?	¿Configuración principal del instrumento?
ID?	¿Código de identificación del instrumento?

Funciones de mantenimiento

BAT?	Estado batería (BAT1=Ok, BAT0=batería baja)
OFF	Apagado completo (arranque con botón o RS)
RST	Reinicialización del equipo
SBY	Hibernación del equipo (SIS)
VER?	Revisión y fecha del firmware.

11. Specifications

Alcance de la medición:	12.5mm	25mm	50mm	100mm	150mm	
Error máx. (escala 0,01mm):	10µm	10µm	20µm	20µm	20µm	(±1 digit)
Error máx. (escala 0,001mm):	4µm	5µm	7µm	8µm	10µm	
Repetibilidad:	2µm					
Peso:	119g	123g	161g	208g	265g	
Fuerza de medición (estándar):	0.65-0.9N	0.65-1.15N	1.25-2.7N	1.6-3.5N	2.2-5.7N	
Velocidad máxima de desplazamiento:	1.7m/seg.					
N1 de mediciones por segundo:	medición: 10 mes/s modo MIN/MAX: 20 med/seg.					
Unidad de medida:	métrico / imperial (pulgadas)					
Preset máximo (escala 0,01mm):	±9999.99 mm / ±399.9995 IN					
Preset máximo (escala 0.001mm):	±999.999 mm / ±39.99995 IN					
Sistema de medida:	Sylvac inductive system (patentado)					
Alimentación:	1 batería litio 3V, tipo CR2032, capacidad 220mAh					
Consumo medio:	75µA					
Autonomía media:	8'000 hours					
Salida de datos:	compatible RS232					
Temperatura de trabajo (almacenamiento):	+5 hasta +40°C (-10 hasta +60°C)					
Compatibilidad electromagnética:	según EN 61326-1					
Especificación IP (según IEC60529):	IP 51 / IP 67 (depending on model)					
Fijación y volumen:	fijación Ø8h6 (3/8"), tecla de medición intercambiable M2.5 (4-48-UNF) (según DIN 878)					

CERTIFICATE OF CONFORMITY

We certify that this instrument has been manufactured in accordance with our Quality Standard and tested with reference to masters of certified traceability by the National Office of Metrology.

CERTIFICAT DE CONFORMITE

Nous certifions que cet instrument a été fabriqué et contrôlé selon nos normes de qualité et en référence avec des étalons dont la traçabilité est reconnue par l'office national de métrologie.

QUALITÄTSZEUGNIS

Wir bestätigen, dass dieses Gerät gemäss unseren internen Qualitätsnormen hergestellt wurde und mittels Normalen mit anerkannter Rückverfolgbarkeit, kalibriert durch das Nationalamt für Metrologie, geprüft worden ist.

CERTIFICATO DI CONFORMITÀ

Con il presente si certifica che questo strumento è stato prodotto secondo il nostro standard sulla qualità e controllato rispetto a campioni di riferibilità riconosciuta dall'ufficio nazionale di metrologia

CERTIFICADO DE CONFORMIDAD

Certificamos que este instrumento ha sido fabricado conforme a nuestras normas de calidad y ha sido controlado en relación con patrones de trazabilidad reconocida por la oficina nacional de metrología.

Calibration certificate

Because we make our instruments in batches, you may find that the date on your calibration certificate is not current. Please be assured that your instruments are certified at point of production and then held in stock in our warehouse in accordance with our Quality Management System ISO 9001. Re-calibration cycle should start from date of receipt.

Certificat d'étalonnage

En raison de la fabrication de nos instruments par lots de production, il est possible que la date de votre certificat d'étalonnage ne soit pas actuelle. Nous garantissons que nos instruments sont certifiés au moment de leur fabrication puis stockés conformément à notre système de gestion de la qualité ISO 9001. Le cycle de réétalonnage peut commencer à partir de la date de réception.

Zertifikat

Da wir unsere Instrumente in Serien herstellen, kann es sein, dass das Datum auf dem Zertifikat nicht aktuell ist. Die Instrumente sind jedoch ab der Herstellung zertifiziert und werden dann gemäß unserem Qualitätsmanagementsystem ISO 9001 in unserem Lager aufbewahrt. Der Nachkalibrierungszyklus kann ab dem Empfangsdatum beginnen.

Certificado de calibración

Puesto que fabricamos nuestros instrumentos por lotes, puede que la fecha de su informe de prueba / certificado de calibración no esté al día. Asegúrese de que los instrumentos estén certificados en nuestro lugar de producción y estén almacenados en nuestro almacén conforme a nuestro sistema de control de calidad ISO 9001. El ciclo de recalibración puede empezar a partir de la fecha de recepción.

Certificato di taratura

Considerata la nostra produzione in serie di strumenti, è possibile verificare che la data di produzione sul rapporto di prova / certificato di taratura non è attuale. Accertarsi che gli strumenti siano correttamente certificati dalla nostra produzione e che sono conservati in stock presso il nostro magazzino secondo il sistema di gestione della qualità ISO 9001. Il ciclo di nuova taratura può essere avviato dalla data di ricezione.



Changes without prior notice

Sous réserve de toute modification

Änderungen vorbehalten

Soggetto a modifica senza preavviso

Reservados los derechos de modificación sin previo aviso

Edition :2024.10 / 681-289-02-100